

## Copelametic® Two-Stage Compressors Application and Service Instructions

The Copeland® two stage compressors have been developed to efficiently achieve the low temperature demanded by many of today's applications. These are designed primarily to operate systems with evaporating temperatures 0°F to -80°F (Refer to Figure 1 for R-22 and 502 and Figure 2 for R404A and 507 for operating envelopes). With the phase out of CFC and HCFC refrigerants and the growing popularity of HFC's, Emerson Climate Technologies has approved the 9T series two stage compressors for use with R-404A and R-507 in addition to R-22 and R-502. Refer to Table 1 for a list of approved refrigerants and models. Due to the higher operating pressures of R-404A, the tube in tube heat exchanger will become obsolete and replaced with a braze plate style heat exchange. Performance data can be accessed at [www.emersonclimate.com](http://www.emersonclimate.com) in the Online Product Information section.

Two-stage compressors are divided into low (or first) and high (or second) stages. The threecylinder models have two cylinders on the low-stage models and one on the high, while the six-cylinder models have four cylinders on the low and two on the high. In each case the low-stage has twice as much displacement as the high-stage.

The suction gas enters the low-stage cylinders where it is raised to a pressure between the suction and condensing pressures (called inter-stage or intermediate pressure). It is then discharged from the low-stage heads into the inter-stage manifold.

At this point the gas has a relatively high temperature and liquid refrigerant is metered by an expansion valve (called desuperheating expansion valve) into the gas stream to reduce the superheat.

The cooled gas then passes through the external manifold, into the motor chamber, through the motor providing the necessary motor cooling in a normal manner, where it is raised to condensing pressure and pumped out of the high-stage head to the condenser. Note that the discharge of the low-stage is pumped into the motor chamber and, therefore, the motor chamber

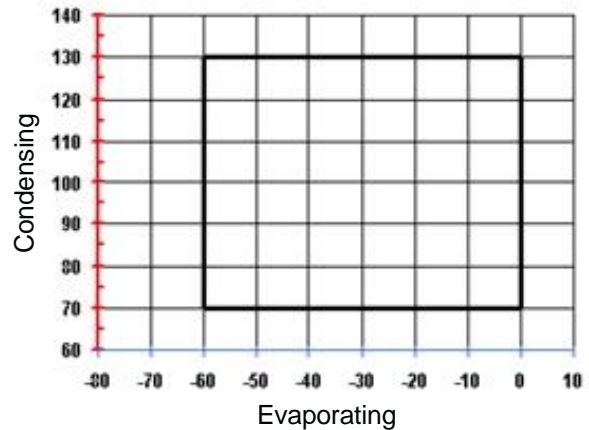

Figure 1  
6TM/6BR/9T\*1 R-22 Operating Envelope

Table 1

Model	Refrigerant	Oil
9TK1-050E	22/502/404A/507	POE
9TK1-0505	22/502	MO
9TL2-076E	22/502/404A/507	POE
9TL1-0765	22/502	MO
9TH2-101E	22/502/404A/507	POE
9TH1-1015	22/502	MO
6RB2-1000	22/502	MO
6RB2-2000	22/502	MO
6RB5-2000	22/502	MO
6TM1-2000	22/502	MO

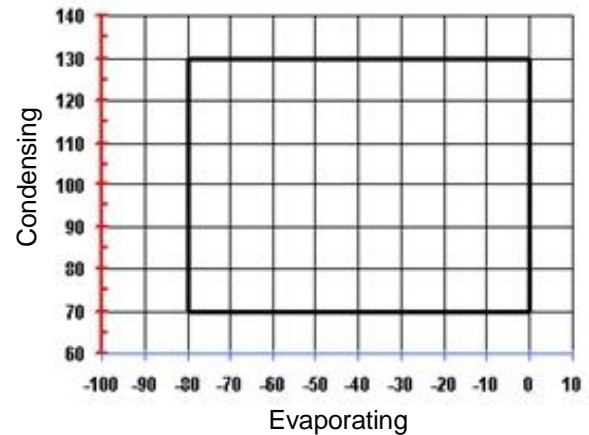

Figure 2  
9T\*2 R-404A Operating Envelope

and crankcase are at the inter-stage pressure. The motor is adequately cooled by refrigerant vapor and forced air cooling is not required as on low temperature compressors.

NOTE: When adding refrigerant in a liquid state into the suction of the first stage, an atomizer must be used or internal damage could result. The first stage uses a direct suction which leads into the cylinder. Any liquid returned through this port will cause a hydro lock condition.

Tables 2, 3, and 4 show the approximate inter-stage (motor chamber and crankcase) pressure at the various suction and head pressures for R-22 R-502 and R-404A. Two low side and one high side gauge will be needed to check the pressures.

#### Connection Ports

The high and low pressure control connections and the discharge and suction service valves are located differently than on single-stage compressors. Figure 4, 5, 6, 7, and 8 show these and indicate the inter-stage pressure ports as well as the low and high-stage cylinders (reference AE 4-1094 for further information on part locations).

Two-stage compressors now being produced have a Schrader type valve installed to permit easy checking of inter-stage pressure. Valves can be added to any in use which were not so equipped.

#### Liquid Sub-Cooler

To increase system capacity and efficiency, a brazed plate heat exchanger is often used with a two-stage compressor as a liquid sub-cooler and is installed between the desuperheating expansion valve and the compressor inter-stage manifold. The evaporating refrigerant cools the discharge gas from the low-stage cylinders and also cools the liquid refrigerant on its way to the evaporator. The liquid leaving the sub-cooler is approximately ten degrees above the saturated inter-stage temperature, (saturation temperature equal to the inter-stage pressure). The liquid line should be insulated to take full advantage of the liquid sub-cooler. See Figures 3, 4, 5, and 6 for recommended systems with and without liquid sub-coolers.

#### Liquid Solenoid Valve

To prevent leakage through the desuperheating expansion valve during the off period, a solenoid valve must be placed in the liquid supply line immediately ahead of the desuperheating expansion valve. It should be wired so as to be open when the motor is running and closed when not running. A toggle switch placed in the electric line to the solenoid valve, will facilitate service during pump down.

A 100 mesh strainer must be installed in the liquid line feeding the desuperheating valve, up stream of the solenoid valve, to protect both valves from contaminants.

#### Oil Pressure Safety Controls

These are standard equipment on all Copelametic two-stage condensing units and are mandatory on all two-stage compressors.

#### Oil Separators

Oil separators are recommended on these compressors as they not only provide some increase in refrigerant capacity and reduce the quantity of oil in circulation, but also act as a muffler to reduce discharge pulsation and system noise level.

#### Suction Line and Accumulators

To prevent damage to these compressors caused by slugging with liquid refrigerant and/or oil, adequate suction line accumulators (designed to prevent oil trapping) are mandatory on any system prone to return slugs of liquid or oil to the compressor.

If the suction vapor returning to the accumulator is 5°F or below, it may be necessary to heat the accumulator in order to return oil to the compressor.

Note: The suction line must be well insulated with at least 1" insulation including the accumulator, filter and suction line vibrasorber if used.

#### Suction Line Filters

Suction line filters should be installed to prevent minute particles of scale, flux, dirt, chips of copper, etc., from entering the compressor. Care should be taken in their selection to prevent excessive pressure drop.

#### Liquid Sight Glasses

A liquid sight glass should be installed in the liquid line just ahead of the desuperheating expansion valve to provide a positive check for shortage of liquid.

When a liquid sub-cooler is used the regular liquid line sight glass (additional to the one ahead of the desuperheating expansion valve) should be installed between the receiver and sub-cooler. If installed beyond the sub-cooler it will not be dependable as it will not show bubbles even when the system is short of gas.

#### Crankcase Pressure Regulating Valves

With low voltage conditions the motors of two-stage compressors can be overloaded, and protector tripping can be expected if the saturated suction temperature at the compressor inlet exceeds the following limits for more than 3 or 4 minutes:

TABLE 2  
INTER-STAGE PRESSURE R-22 (TWO-STAGE 2/1 RATIO)

SUCTION PRESSURE PSIG	WITHOUT SUB-COOLER					WITH SUB-COOLER				
	HEAD PRESSURE (PSIG)					HEAD PRESSURE (PSIG)				
	170	202	235	268	300	170	202	235	268	300
12#	55	58	61	64	67	65	68	71	75	78
10#	51	53	56	59	62	60	63	66	69	73
8#	46	49	52	54	57	55	58	60	64	67
6#	42	45	47	50	52	50	53	55	58	61
4#	38	40	43	45	47	45	48	50	53	56
2#	33	35	38	40	42	40	42	45	47	50
0#	28	31	33	35	37	35	37	40	42	45
3"	25	28	30	32	34	32	33	36	38	41
6"	22	24	26	28	30	27	30	32	34	36
9"	18	21	23	25	26	24	26	28	30	32
12"	16	18	20	21	23	21	23	24	26	29

TABLE 3  
INTER-STAGE PRESSURE R-502 (TWO-STAGE 2/1 RATIO)

SUCTION PRESSURE PSIG	WITHOUT SUB-COOLER					WITH SUB-COOLER				
	HEAD PRESSURE (PSIG)					HEAD PRESSURE (PSIG)				
	186	219	252	286	318	186	219	252	286	318
16#	62	65	68	71	74	67	72	77	83	88
14#	57	60	63	66	69	62	68	73	78	84
12#	53	56	59	62	65	58	63	68	73	79
10#	48	51	54	57	60	54	59	64	69	74
8#	44	47	50	53	55	50	55	58	64	68
6#	39	42	45	48	51	46	50	55	59	65
4#	35	38	41	44	47	42	46	51	55	60
2#	30	33	36	39	42	37	42	49	50	55
0#	26	29	32	35	38	33	38	41	45	50
2"	23	26	29	33	36	31	35	39	43	48
4"	21	24	27	30	34	29	33	37	41	46
6"	19	22	25	28	31	27	31	35	39	43
8"	17	20	23	26	29	25	29	33	36	41

Allowable tolerance for inter-stage pressure is  $\pm 7$  PSIG.

TABLE 4

Inner Stage Pressure R-404A W/ Subcooler					
Suction Pressure	Head Pressure (PSIG)				
PSIG	200	230	270	300	350
16.0	74.4	77.8	84.0	89.7	94.4
14.0	68.0	70.9	75.8	80.9	88.7
12.0	64.4	69.4	73.4	81.5	84.5
10.0	59.4	63.3	69.0	73.6	79.6
8.0	54.4	58.0	65.0	69.0	76.3
6.0	42.7	46.5	61.1	65.1	71.9
4.0	40.8	45.1	50.3	50.8	67.2
2.0	42.1	43.8	49.0	53.6	59.1
0.0	38.6	41.2	44.4	48.4	53.6
2"	31.5	34.7	38.8	41.3	46.4
4"	26.6	26.4	31.9	33.5	35.3
6"	21.3	22.3	24.5	26.2	28.0
8"	14.8	15.6	16.5	17.6	20.1

Low temperature compressors 0°F.

Extra-low temperature compressors -30°F.

The suction pressure on some systems can be limited to a satisfactory point by the size and type of evaporator used or by the use of pressure limiting expansion valves. Others will require crankcase pressure regulating valves. In selecting a regulating valve, limit the pressure drop to 2°F. (equivalent) maximum at normal operating conditions.

#### Desuperheating Expansion Valves

On all Copelametic two-stage compressors, liquid refrigerant is metered into the inter-stage manifold by means of an expansion valve to reduce the superheat of the discharge gas from the low-stage cylinder. The expansion valves currently supplied as original equipment with Copelametic two-stage compressors are of the non-adjustable superheat type.

If the expansion valve becomes clogged or for other reasons fails to function properly, the liquid line solenoid and strainer should be checked for obstructions and cleaned, and the valve should be thoroughly washed out. If cleaning fails to restore satisfactory performance, the valve must be replaced.

In the event the proper Emerson replacement valve is not available from the local Emerson wholesaler's stock, standard field replacement valves with adjustable superheat which have been approved by Emerson may be used.

Normally it will be necessary to change the factory setting of the adjustable superheat type of valve to obtain proper performance. The valve should be adjusted to obtain a temperature difference (superheat) of 15°F. to 30°F. between the temperature of the manifold (at the bulb) and the saturated temperature of the refrigerant at inter-stage pressure.

Example - Using R-22 with Inter-Stage Pressure of 31 psig.

Desired Superheat Limits: 15°F. 30°F.

R-22, 31 Psig Saturation Temperature: 8°F. 8°F.

Desired Manifold Temperature Limits: 23°F. 38°F.

The desuperheating expansion valve should be adjusted to maintain a manifold temperature at the bulb between 23°F. and 38°F.

The superheat can be raised by turning the superheat adjustment stem clockwise, and can be lowered by turning the stem counterclockwise.

Because the characteristics of R-502 and R-404 are such that it has less temperature rise during compression, tests have proven that for this application the same expansion valve may be used for either R-22, R-502, and R-404A with satisfactory results.

Note: Care should be taken in connecting the liquid supply line for the desuperheating expansion valve. It should be not smaller than 3/8" O.D. And should be installed at the bottom of a horizontal line, to insure a constant supply of liquid at all times. This line should never be connected to the top of a horizontal line because vapor only will be picked up when the line is short of liquid. Connection to a vertical line of low velocity will be satisfactory.

#### Defrost Cycle

With electric defrost, the compressor is not running during the defrost cycle, so no special precautions other than those normally required with single stage systems are necessary.

However, motor cooling on two-stage compressors is dependent on an adequate feed of liquid refrigerant from the desuperheating expansion valve. If a hot gas defrost system is used, it is imperative that a solid head of liquid is maintained at the desuperheating expansion valve at all times. Since hot gas defrost systems vary

Table 5  
Desuperheating Expansion Valves  
Field Replacements for Copelametic Two-Stage Compressors

Non-Adjustable			Adjustable	
Copelametic Model No.	Emerson Part No.	Sporlan Part No.	Sporlan Part No.	Emerson Part No.
9TK	510-0144-00	IV-2-Z	CV-2-Z	2 Turns In
9TH, 9TL	510-0144-02	IV-3-Z	CV-3-Z	2 Turns In
6RB	510-0144-03	NCV-4-Z	CV-5-Z	1 1/4 Turns In
6TM	510-0144-04	NCV-5-C	CV-5-Z	1 1/4 Turns In

widely in design, it is not possible to make a general statement as to what special controls may be required. Most manufacturers have thoroughly pretested their systems, but on field installations, restrictor valves to maintain head pressure, additional refrigerant charge, or other special controls may be necessary.

### Two-Stage Compressor Pulsation

All reciprocating compressors create pulsation in the discharge gas line. Under normal operating conditions, such pulsations are not of sufficient force to cause any problems. The magnitude of the pulsation increases with a decrease in the number of cylinders pumping into a common discharge chamber, and with increasing volume and density of the gas pumped.

Two-stage compressors handle gas of high density in the second or high stage. On the 9T model compressors, only one cylinder is discharging into the compressor discharge line, and on the 6R model compressors, only two cylinders are pumping into the discharge line. Because of these conditions, pulsation on two-stage compressors may be more pronounced than on single-stage compressors.

Normally these pulsations are not a problem. Occasionally, however, a combination of operating conditions, mounting, and piping arrangement may result in a resonant condition, which tends to magnify the pulsation and cause vibration. To solve this problem, discharge muffler plates have been developed for the 9T and 6R two-stage compressors. The muffler plate fits between the discharge service valve and the compressor body.

The muffler plate will effectively dampen pulsation and reduce vibration. It is now being installed as standard equipment on all new two-stage compressors. If pulsation is a problem on existing equipment, it is recommended that discharge plates be installed. These are available from your Emerson wholesaler under part numbers shown below in Table 6.

If the piping size and connections on a particular unit are such that resonance does occur, and the muffler plate does not dampen it sufficiently, it may be necessary to bolt the compressor to its mounting base with rubber vibration eliminating mounting pads in order to change the vibration frequency.

### Valve Plates And Gaskets

Valve plates on some models are the same as used on equivalent single-stage models but the head gaskets are different. Always match the head gasket with the head to be sure there is a gasket section to match each partition in the head. Incorrect gaskets cause leakage between stages.

### Warning - Danger

Do not operate a service replacement two-stage compressor without first installing the external inter-stage manifold. There is no provision internally for escape of the high pressure gas from the low-stage cylinders, and without the external manifold dangerous pressures can be created which could result in possible injury to the operator.

Table 6

Emerson Part Number	Description	Application Data
003-0107-00	Muffler Plate	For all 9T Compressors
003-0383-00	Muffler Plate	For all 6RB and 6TM Compressors
020-0012-09	Gasket (2 required)	1" hole size, 2 3/4" Centers
027-0115-00	Upper Rubber Vibration Mount (4 required)	11/16" hole
027-0114-00	Lower Rubber Vibration Mount (4 required)	11/16" hole

Table 7

Comp. Model	Valve Plate and Gasket Kits		Body-to-Valve Plate Gasket		Valve Plate Head-To-Head Gasket			
	Part No.	No. Req.	Part No.	No. Req.	Low Stage		High Stage	
					Part No.	No. Req.	Part No.	No. Req.
9TK	998-0061-36	1	020-0128-01	1	020-0270-00	1	Same	
9TL	998-0061-36	1	020-0128-00	1	020-0270-00	1	Same	
9TH	998-0061-36	1	020-0128-04	1	020-0270-00	1	Same	
6RB2 6RB5	998-0061-52	3	020-0626-00	3	020-0631-00	2	020-0630-00	1
6TM	998-0061-49	3	020-0433-00	3	020-0450-00	2	020-0441-00	1

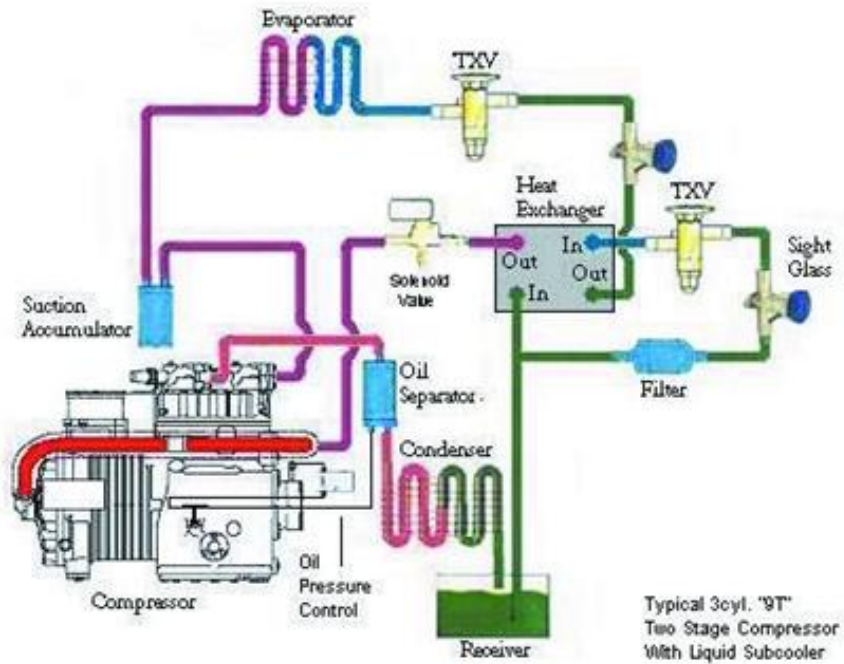

FIGURE 3  
9T\*2 WITH BRAZEPLATE SUBCOOLER

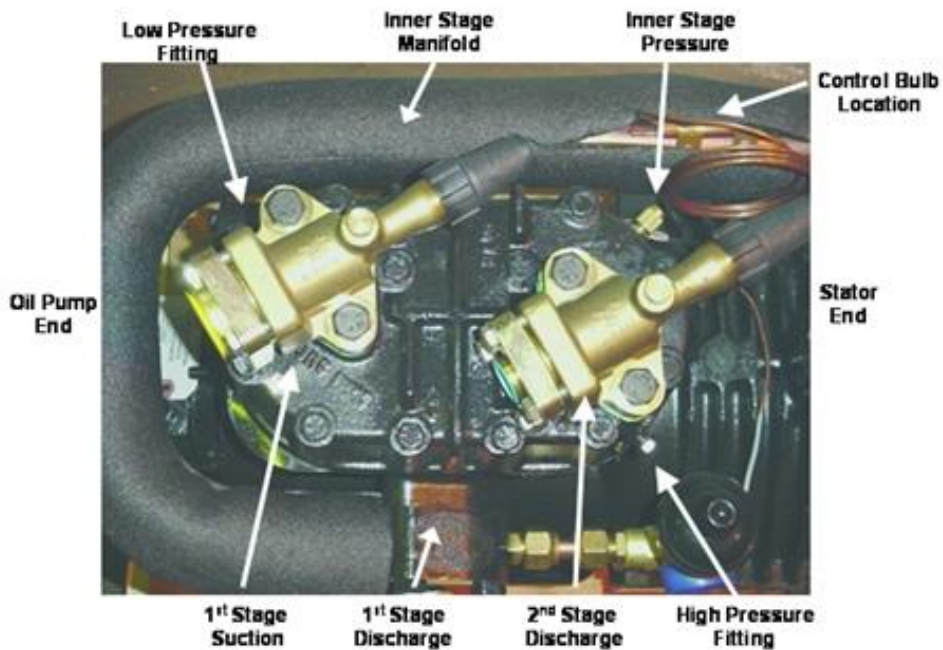

FIGURE 4  
9T PORT IDENTIFICATION

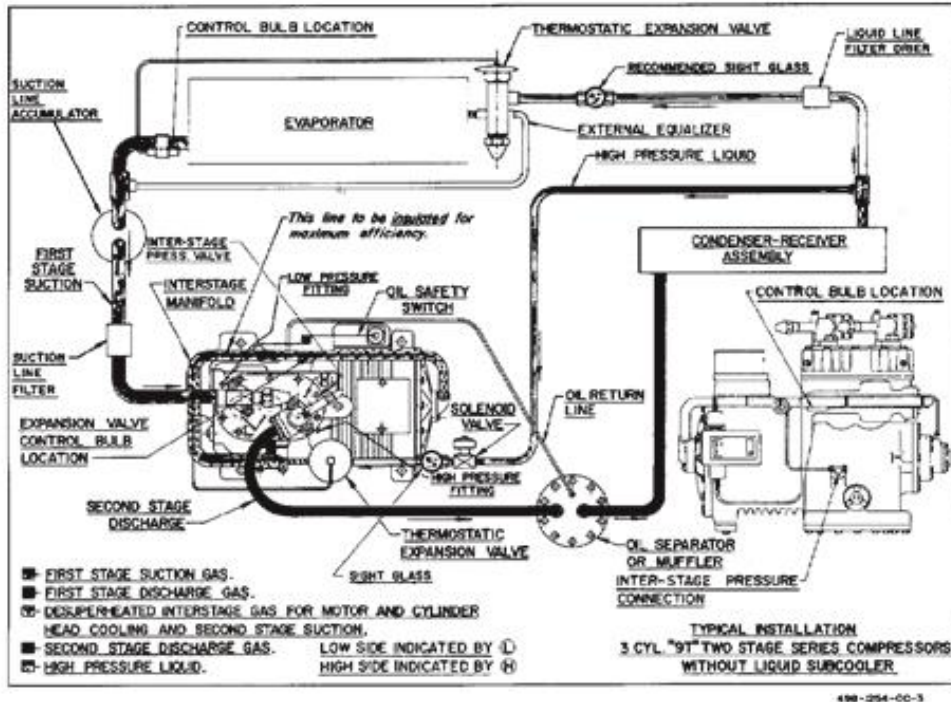

FIGURE 5  
SYSTEM WITH 3-CYLINDER COMPRESSOR (WITH LIQUID SUB-COOLER)

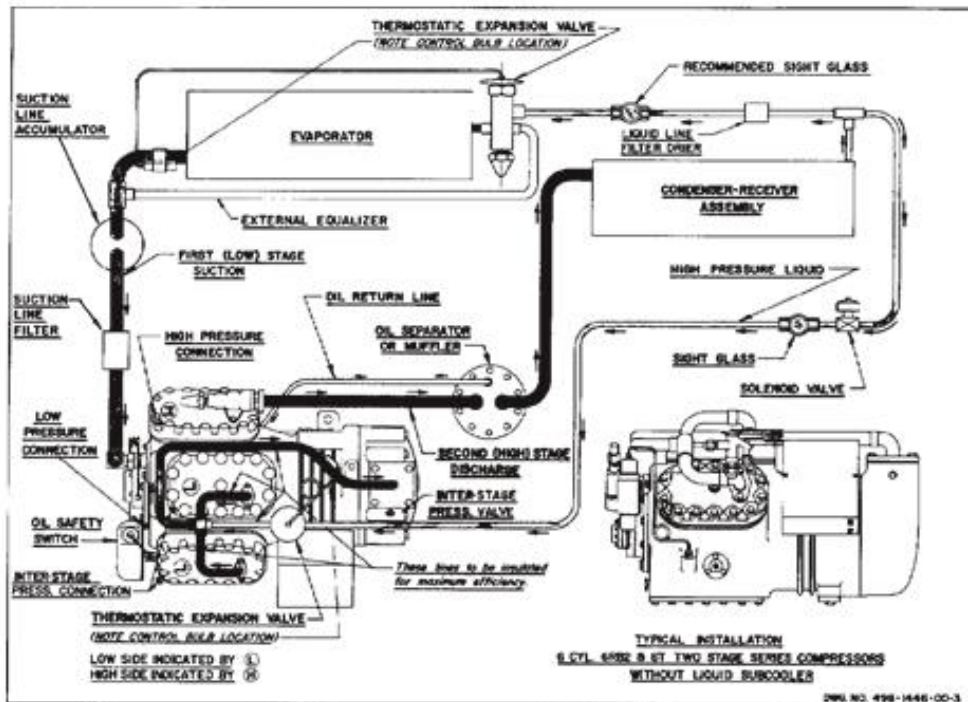

FIGURE 6  
SYSTEM WITH 6-CYLINDER COMPRESSOR (WITH LIQUID SUB-COOLER)

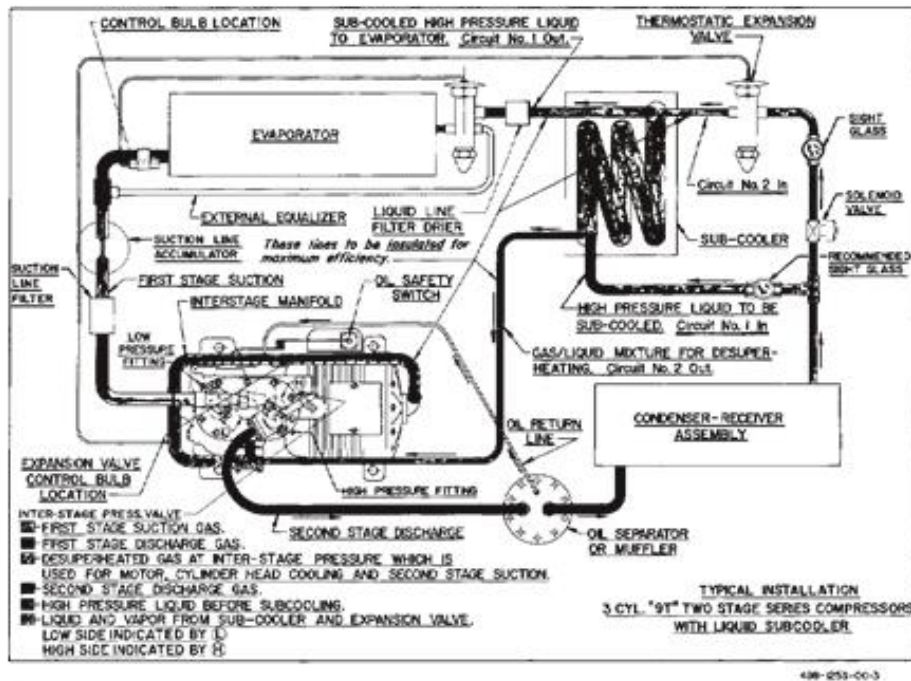

FIGURE 7  
SYSTEM WITH 3-CYLINDER COMPRESSOR (WITH INNER-TUBE LIQUID SUB-COOLER)

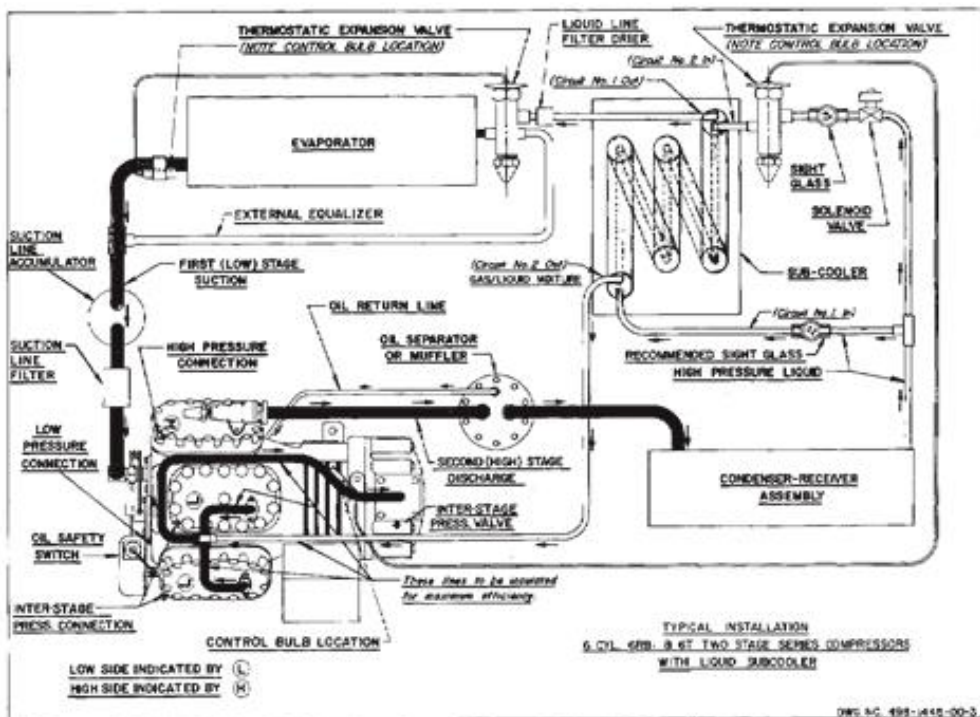
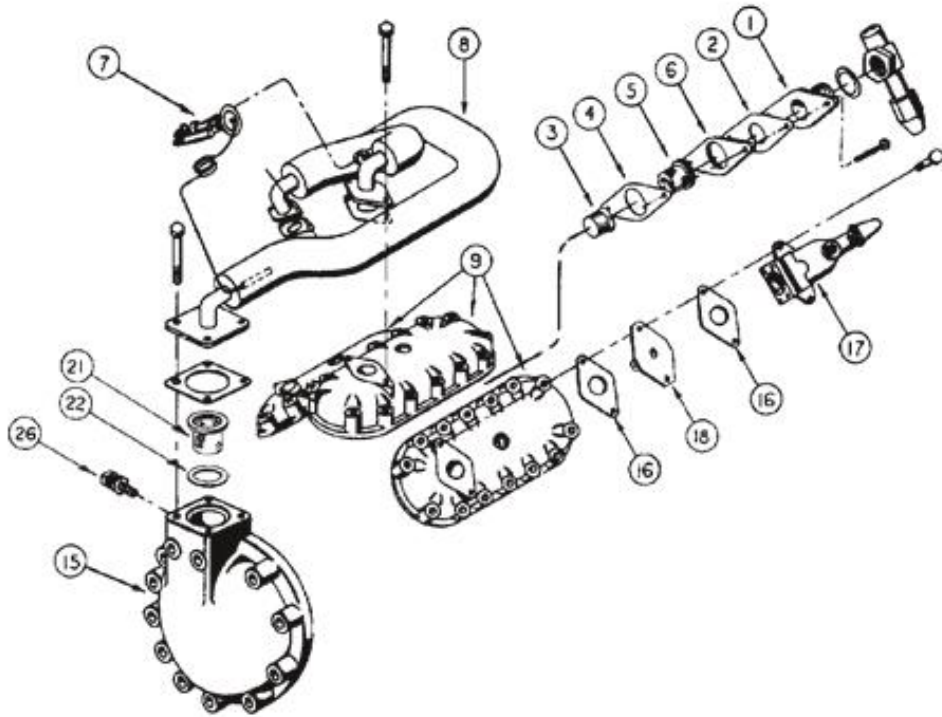
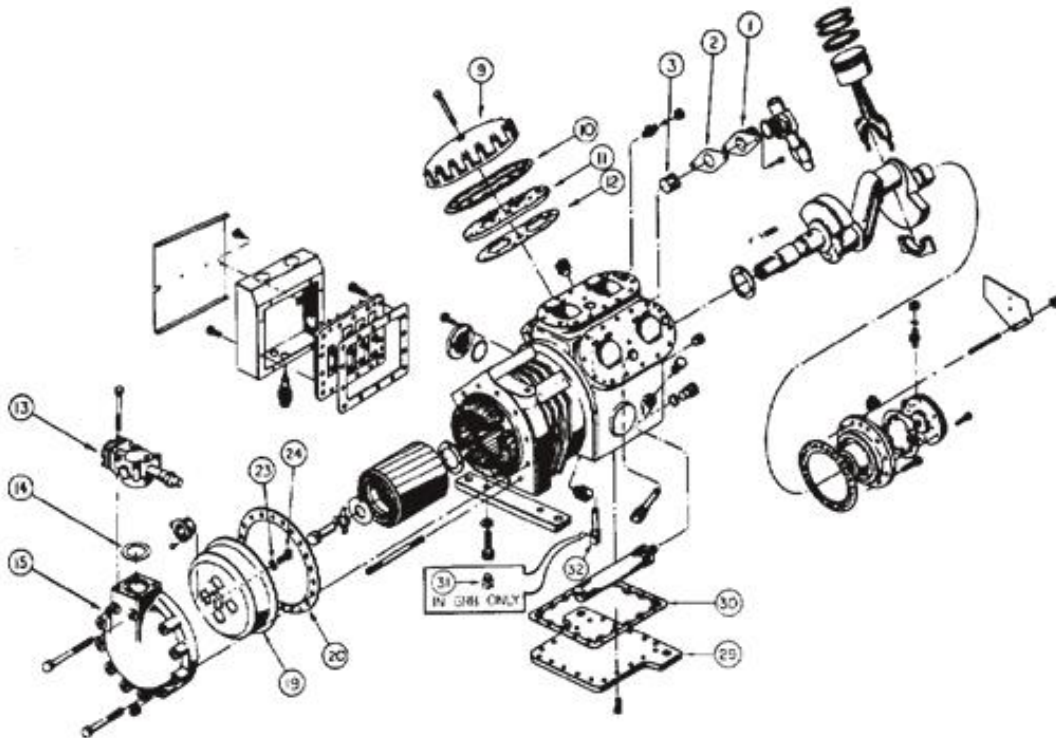

FIGURE 8  
SYSTEM WITH 6-CYLINDER COMPRESSOR (WITH INNER-TUBE LIQUID SUB-COOLER)





Two-Stage Conversion



Exploded View Model "6R" Series (Single-Stage) Compressor



Service

No unusual service should be required on a well installed two-stage system. The electrical equipment is identical to single-stage compressors and requires no special comment..

If a valve plate is suspected of being defective, it can easily be checked by observing the head, suction and interstage pressures. If the inter-stage pressure does not correspond within 7 lbs. to that shown in tables 1 and 2, a malfunction is indicated.

The Following Service Chart Will Assist in Diagnosis of Other Possible Troubles:

Complaint	Cause	Correction
1. Suction pressure abnormally low	<ol style="list-style-type: none"> <li>Short of charge</li> <li>Restriction in liquid line</li> <li>Excessive pressure drop in suction line</li> <li>Inoperative expansion valve</li> <li>Evaporator fan not running</li> <li>Plugged or iced evaporator</li> <li>Discharge pressure too low</li> </ol>	<ol style="list-style-type: none"> <li>Add charge</li> <li>Remove restriction (can be caused by plugged drier)</li> <li>Increase line size or remove restriction</li> <li>Replace valve</li> <li>Repair or replace</li> <li>Clean or defrost</li> <li>See complaint number 3</li> </ol>
2. Suction pressure abnormally high	<ol style="list-style-type: none"> <li>Inter-Stage pressure too low</li> <li>Inter-Stage pressure too high</li> <li>Evaporator expansion valve bulb loose</li> <li>Evaporator expansion valve malfunction</li> <li>Discharge pressure too high</li> <li>Wrong head gasket</li> </ol>	<ol style="list-style-type: none"> <li>See complaint number 6</li> <li>See complaint number 5</li> <li>Clamp properly</li> <li>Replace</li> <li>See complaint number 4</li> <li>Install correct gasket</li> </ol>
3. Discharge pressure abnormally low	<ol style="list-style-type: none"> <li>Short of charge</li> <li>Low ambient on air-cooled condenser</li> <li>Water regulator valve set too low</li> </ol>	<ol style="list-style-type: none"> <li>Add charge</li> <li>Install winter control, various types are available</li> <li>Adjust water valve</li> </ol>
4. Discharge pressure abnormally high	<ol style="list-style-type: none"> <li>Plugged condenser</li> <li>Excessively high temperature air entering air-cooled condenser</li> <li>High temperature water entering condenser</li> <li>Water valve set too high</li> <li>Condenser fan not running</li> </ol>	<ol style="list-style-type: none"> <li>Clean condenser</li> <li>Prevent air from recirculating and assure adequate ventilation</li> <li>Check water supply</li> <li>Adjust</li> <li>Repair or replace</li> </ol>
5. Inter-stage pressure too high	<ol style="list-style-type: none"> <li>Blown gasket (discharge to inter-stage)</li> <li>Malfunctioning or broken high-stage reeds</li> </ol>	<ol style="list-style-type: none"> <li>Replace</li> <li>Replace valve plate assembly</li> </ol>
6. Inter-stage pressure too low	<ol style="list-style-type: none"> <li>Blown gasket (inter-stage too low)</li> <li>Malfunctioning or broken low-stage reeds</li> <li>Wrong high-stage head gasket</li> </ol>	<ol style="list-style-type: none"> <li>Replace gasket</li> <li>Replace valve plate assembly</li> <li>Install correct gasket</li> </ol>
7. Compressor runs hot, trips thermal protectors when not drawing excessive current, discharge temperature above 270°F	<ol style="list-style-type: none"> <li>Liquid not being fed to desuperheating expansion valve</li> <li>Improper bulb location</li> <li>Improper setting of adjustable type expansion valve</li> <li>Defective valve</li> <li>Plugged liquid screen, filter, or drier</li> </ol>	<ol style="list-style-type: none"> <li>Add charge if needed; move line so that liquid is fed from bottom of horizontal line. Check liquid filter or drier for restriction.</li> <li>Locate properly</li> <li>See adjusting instructions</li> <li>Replace valve</li> <li>Clean or replace</li> </ol>
8. Ice on stator cover or crankcase	<ol style="list-style-type: none"> <li>Bulb not clamped properly, improper location</li> <li>Improper setting of adjustable type expansion valve</li> <li>Defective valve</li> </ol>	<ol style="list-style-type: none"> <li>Clamp properly, locate properly</li> <li>See adjusting instructions</li> <li>Replace valve</li> </ol>

The contents of this publication are presented for informational purposes only and are not to be construed as warranties or guarantees, express or implied, regarding the products or services described herein or their use or applicability. Emerson Climate Technologies, Inc. and/or its affiliates (collectively "Emerson"), as applicable, reserve the right to modify the design or specifications of such products at any time without notice. Emerson does not assume responsibility for the selection, use or maintenance of any product. Responsibility for proper selection, use and maintenance of any Emerson product remains solely with the purchaser or end user.